

BL 966 S



- Sensing distance
 On reflector \varnothing 46 : 2 cm to 1m
 On reflector \varnothing 84 : 2 cm to 2m
- Supply : 10 / 30 VDC
- Output : PNP / NPN
- Friendly adjustment by key + / -
- Bargraph



Description :

- Thickness reduced to 13 mm
- Immunity to reflections
- Simple adjustment
- Sensitivity bargraph
- Maximum and minimum sensitivity indication
- Keyboard lock
- Direct or inverse output
- Output : PNP / NPN
- Cable or M8 socket
- Polycarbonate strong housing

Applications :

- Position or presence control of parts on conditioning machine.
- Through-beam on a conveyor.
- Detection of shiny parts.

Dimensions

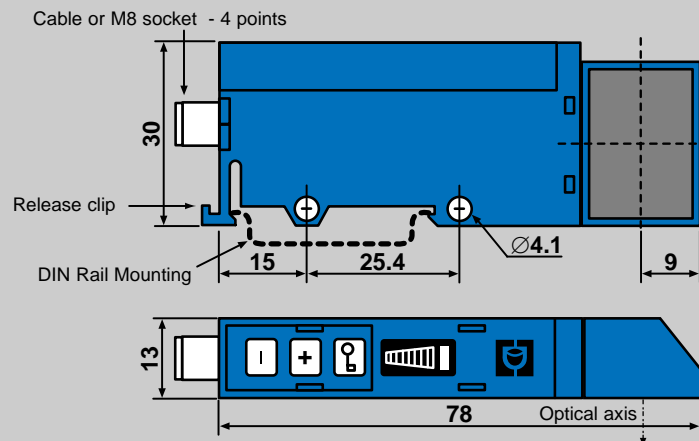

Wiring Diagram

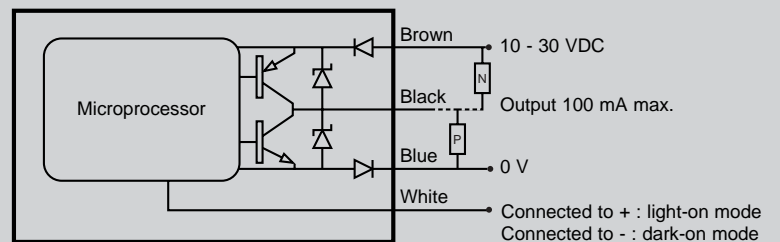

Display and Keyboard

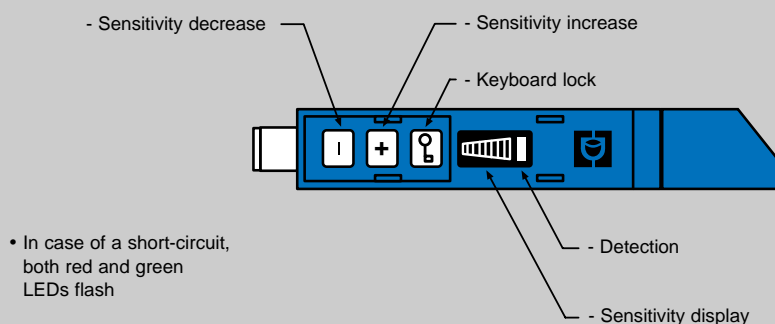

Technical Information

Supply	voltage	10 / 30 VDC ripple < 10% within specified limits
	consumption	< 40 mA
Response time	t _{on} or t _{off}	< 500 µs
	switching frequency	< 1 KHz
Output	max. nominal intensity	100 mA
	residual voltage at 100 mA	< 2 V
	residual voltage at 10 mA	< 1 V
Emission	LED	red
	modulation frequency	8 KHz
Temperature	operating	0 to 60 °C
	storage	-20 to 80 °C
External light immunity	incandescent light	10 000 lux
	sunlight	20 000 lux
Protections	supply	inverse polarity protection
	output	permanent short-circuit or over-load protection
	degree of protection	IP 65
Light-on / dark-on function		see wiring diagram

To Place Order

Product	Retro-reflex polarised lateral sensor
Reference	BL - () - 966 S () output with cable 2m (C0) output M8 socket without cable
Cable with M8 plug if required, please order together with the sensor	CM 82 - cable 2m CM 82 C - cable 2m with right angle connector CM 85 - cable 5m

TYPES OF APPLICATIONS

Example 1

Pieces count at a conveyor output.

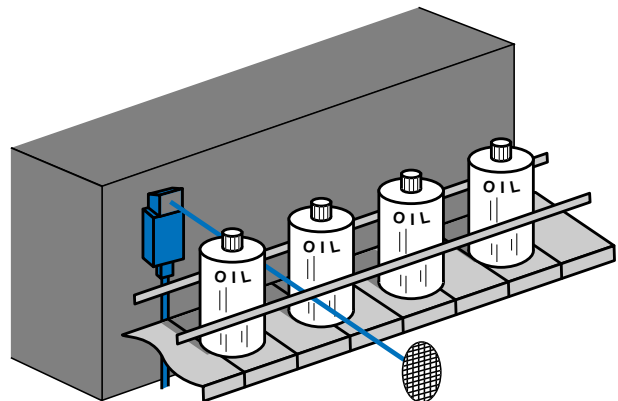
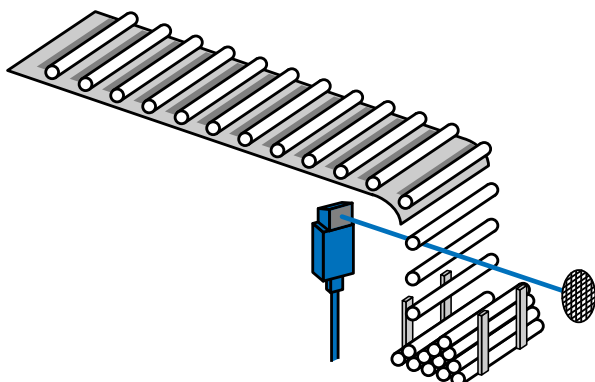

Example 2

Detection of shiny metallic cans.