



# Photoelectric Sensors

## GENERAL SPECIFICATIONS

### WORKING PRINCIPLES

A sensor is made up of an irradiating element, a particular type of light (usually infrared, red or green) and an element photosensitive to the irradiated light. The presence or absence of light on the photosensitive element is used as a signal producing a change in the output of the sensor. Thanks to the qualities of transmission and propagation of the light, different types of sensors can be used.

#### Thru-beam

This type is made up of an emitter and a receiver on the same axis. Every time an object interrupts the light beam, which goes from the emitter to the receiver, a change in the receiver output takes place. This type allows great sensing distances and is particularly suitable for being used in dirty and dusty locations.

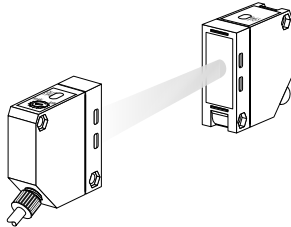

#### Diffuse reflective

In this case the light source and the photosensitive element are included in the same unit. The emitted light reaches the photosensitive element after being reflected from an object present in the irradiation field. The presence or absence of the light on the receiver causes a change in the output state signaling either the presence or absence of an object in the sensing area.

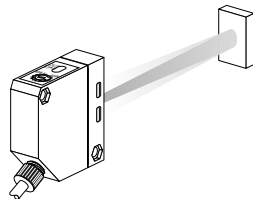

#### Retro reflective

As in Diffuse type the light source and the photosensitive element are in the same unit. Differing from the Diffuse type, the reflection of the light emitted is obtained by using a reflector. As a consequence, the detection occurs when the beam of reflected light is interrupted, that is, when there is an object between the reflector and the sensor.

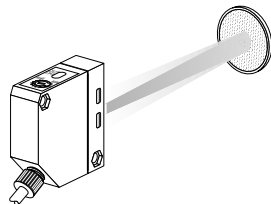

This system is limited by the fact that shining or reflecting objects cannot be identified by the sensor as they reflect the emitted light, as if they were reflectors.

#### Polarized retro reflective

The working principle is the same as in the retro reflective type. This sensor allows shining or reflecting objects to be sensed. This is due to the fact that reflectors deviate the light radiation of 90°. By using special polarizing filters, only the light reflected by the reflector is sensed by the photosensitive element. Therefore common reflecting objects can be sensed because they cannot deviate the light radiation and act as the retroreflector. However if the reflecting surface is of "active material", the light beam through this material may have the same behaviour as the reflector. This is due to the disposition of molecules of that particular material. To avoid this, is advisable to rotate the optical axis (photoelectric sensor-reflector) 45° to the surface to scan.

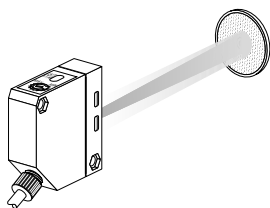

#### Detecting distance for diffuse reflective sensor

Detecting distance for optical proximity sensors varies according to the material to sense. The parameters that influence the maximum capacity of the sensor are mainly the colour and the brightness or roughness of the surface to be detected. Data below are approximate value and are the result of lab tests with mat paper targets 10 x 10 wide of the following colours.

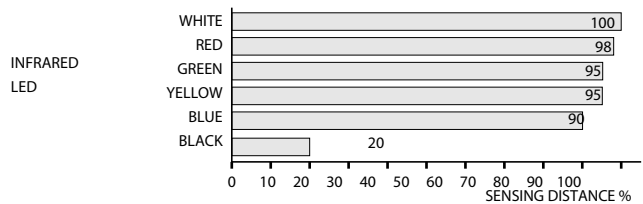
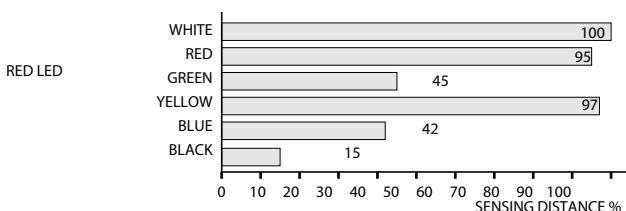

#### Sensing distance for Retro reflective sensor and Thru-beam

It is the maximum distance between photocell and reflector or between emitter and receiver.

#### Hysteresis

It is the maximum distance between the detected and non detected points. These points are obtained by moving the object towards or away from the photocell axis. Data are expressed in percentage to the value of the sensing distance.

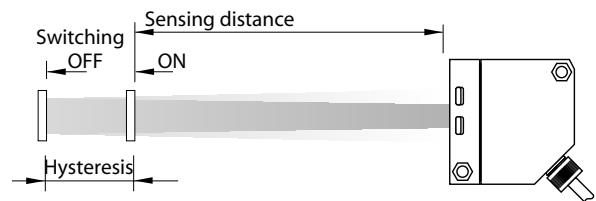

#### Switching frequency

It shows the maximum number of operations per second performed by the photocell.

#### Response time

It is the time the object takes to cover the optical sensor field to perform a correct switching.

### ELECTRICAL PARAMETERS

#### NOMINAL VOLTAGE

It indicates the maximum and minimum voltage values within which sensors work correctly.

#### RESIDUAL RIPPLE

Maximum admissible ripple of the DC supply voltage shown as percentage to its medium value.

#### MAXIMUM OUTPUT CURRENT

It shows maximum output current a sensor can cope with when working steadily.

#### MAXIMUM LEAKAGE CURRENT

Existing load current when output stage is stopped and supply voltage is at maximum nominal value.

#### ABSORPTION

This is the consumption of the photocell referred to the maximum limits of the nominal voltage and without load.

#### VOLTAGE DROP

Voltage drop on switching circuit when output transistor is conducting.

#### SHORT CIRCUIT PROTECTION

A protection in case of short circuits or overload to avoid inner circuit damage. Once the short circuit is eliminated the photocell resets.

#### PROTECTION AGAINST INVERSION OF POLARITY

Available in DC supplied type, it prevents the sensor from being damaged when supply cables are incorrectly connected.

#### INDUCTIVE LOAD PROTECTION

It protects sensor output in presence of high inductive loads. This protection is performed by a diode or zener diode.

#### PROTECTION DEGREE

It shows degree of protection of housing conform to IEC 529 regulation.

#### START UP DELAY

Time interval between sensor supply connection and active output. This time interval is to avoid the switch output being in an undefined state when the system is switched on.

### CONNECTION FOR PHOTOELECTRIC SENSORS WITH NPN OR PNP OUTPUT

#### Connection in series (AND)

Connected in this way sensors activated one output when activated simultaneously. When using this type of connection keep into account as follows:

- 1) drop of voltage for each sensor (<1,5 V);
- 2) the maximum load current of the sensor used together with the absorption of each sensor (<30mA).

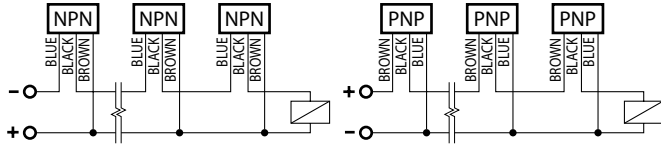

#### Connection in parallel (OR)

Connected in this way sensors can activate the common output independently, when activated. When omitting the diodes indicated in the diagram, use sensors with the final stage which has an open collector (NO).

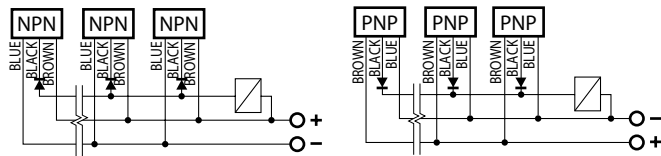

### CONNECTION FOR PHOTOELECTRIC SENSORS WITH PROGRAMMABLE OUTPUT

Thank to the output separated from the rest of circuit, photoelectric sensors so connected provide important advantages, such as the possibility of 4 output configurations (NPN-NO, NPN-NC, PNP-NO, PNP-NC) on the same model and the possibility of connection in series.

#### OUTPUT DIAGRAM

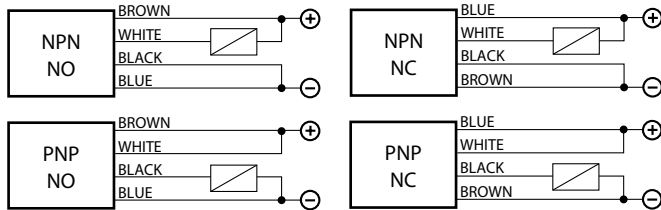

#### Connection in series (AND)

Connected in this way sensors only activate the output when they are energized simultaneously. The maximum number of sensors of this type, connected in this way, is given by the following formula:

$$n = (V \text{ supply} - V \text{ load}) / V \text{ residual}$$

where:

- V supply = voltage
- V load = voltage for min. load energization
- V residual = residual voltage in the cumulative circuit in ON state.

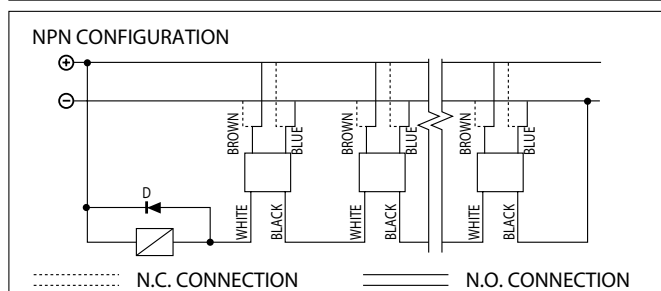
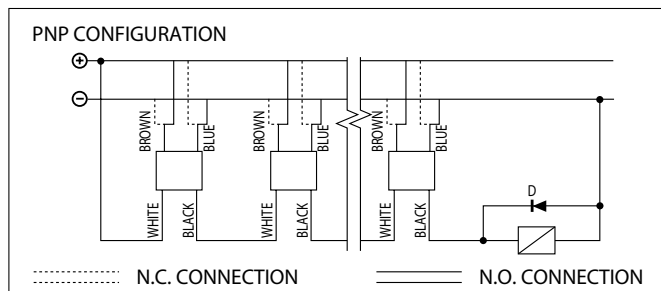

NOTE: In presence of inductive loads, when more sensors are connected in series, diode D should be connected in antiparallel to the load.

#### Connection in parallel (OR)

When connected in this way sensors can activate the common output independently, when energize. Thanks to the really low leakage current, there is no actual limitation in the number of sensor that can be connected in parallel, providing that the min. current of load accumulated is mA.

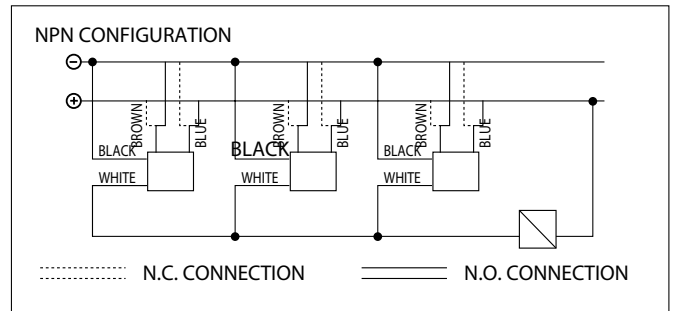
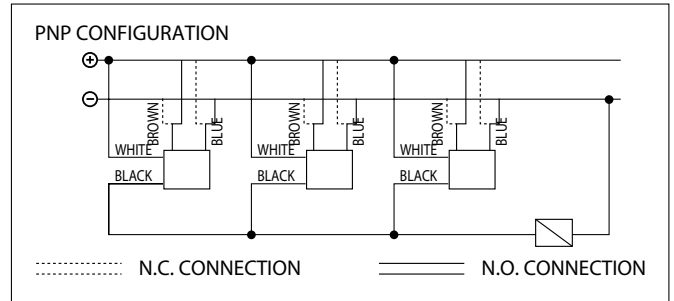

### POWER SUPPLY FOR SENSORS IN DC CURRENT

A stabilised source of voltage can be obtained using the table indicated below. Use the following example to determine the components :

$$VAC = (V \text{ RMS transformer}) = \frac{(V \text{ OUT} + 4.5) \times 1.1}{1.41}$$

$$C1 = \frac{(0.0053) \times I \text{ OUT (value indicated in } \mu\text{F)}}{2}$$

$$VL1 = VAC \times 1.41 \times 1.2$$

If "ℓ" is bigger than 10 cm, add C4 beside the stabiliser

$$C4 = 100 \mu\text{F}; VL4 = VAC \times 1.41 \times 1.2$$

$$C2 = 220 \mu\text{F}; VL2 = VOUT \times 1.2$$

$$C3 = 0.1 \mu\text{F}; VL3 = 63V$$

Note: the regulator must be provided with adequate power or dissipation, it must dissipate:

$$P \text{ DISS.} = \frac{(VAC \times 1.41) - VOUT}{I \text{ OUT max.}}$$

Where IOUT max. is the maximum available (supplied) current

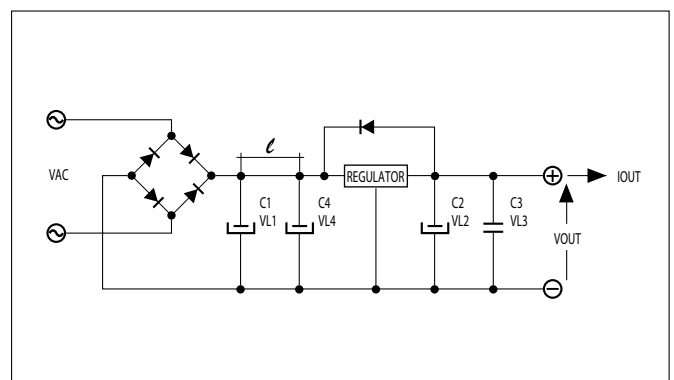

### INSTRUCTIONS FOR CORRECT INSTALLATION

THESE PHOTOELECTRIC SENSORS ARE NOT SAFETY DEVICES, THEREFORE THEY CANNOT BE USED TO PREVENT INJURIES TO PERSONS, DAMAGES, INDUSTRIAL DAMAGES, ACCIDENTS.

#### Connections

- Do not exceed the voltage limits printed on the product label. For DC photoelectric sensors use stable tension.
- Do not connect the photoelectric sensors power supply cables down-stream from other devices and make sure that they are directly connected to the mains.
- If the power supply source is a switching voltage regulator, connect the FG (Frame Ground) terminal to the ground.
- Connect to ground the FG (Frame Ground) terminal and all metallic parts of every industrial machinery or not if a photoelectric sensor is used in it.
- Do not use the photoelectric sensor near electromagnetic or high frequency fields.
- The cables of photoelectric sensors must be separate from the power supply cables, from the engines cables, from the inverters cables, or from any other electromagnetic device because induction noise could cause malfunction or damage to the photoelectric sensors. Separate the wires of the photoelectric sensors from the above indicated cables and then insert the wires into an earthed metal conduit.

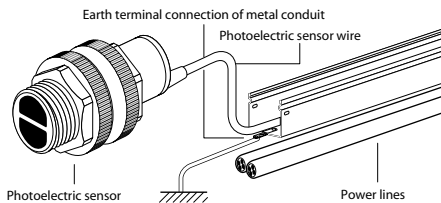

- After making all operations mentioned in the above point 6, if inductive interference exists, an adequate transient suppression filter must be used on the power supply line in proximity to the photoelectric sensors.
- When a large distance by the connection wires to the sensor has to be covered, use conductors with a cross-section of a least 0.50 mm<sup>2</sup> and do not exceed the maximum distance of 100 m.
- The output signal of a photoelectric sensors cannot be used during the start up delay.
- Several sensors should not be connected in series, whereas several sensors can be connected in parallel.

#### Assembly

- For correct assembly and alignment, all the accessories supplied with the sensor must be used.
- To regulate the sensitivity adjustment trimmer use a suitable screw-driver without exerting excessive force.
- Do not turn too much fixing screws or nuts to avoid electrical or mechanical damages.
- Mounting photoelectric sensors side by side, leave an appropriate place between them to avoid mutual interference.
- When installing two or more emitters and the receivers side by side, alternate the emitter with the receiver or install a light barrier to prevent reciprocal interferences. Avoid reflection coming from the side or back walls or objects.
- Do not expose the photoelectric sensors to direct source of fluorescent light which could prevent the correct working. Do not exceed the immunity limits to external light.
- Do not use organic solvents or corrosive liquids to clean the lenses of the photoelectric sensors. The optical parts must be cleaned with a soft cloth and then dried.
- Do not use the sensors in open air without adequate protection.
- Do not use the photoelectric sensors in dusty places, in presence of steam, gases, corrosive steams, corrosive liquids, rain or water jets. Do not let condensation form on the sensor lenses.
- Do not exceed the indicate temperature limits.
- Do not subject the appliance to strong vibrations or to shocks which can damage the sensor or can harm its impermeability.
- Although some range of photoelectric sensors are protect IP-67, this does not mean that these devices can be used to detect objects in water or in the rain.

#### Further information

The manufacturer is not liable for the improper use of the product. Any use and/or application which are not provided for by this instruction sheet must be previously and directly authorized by the same manufacturer.

### SETTING OF NON-ADJUSTABLE PHOTOELECTRIC SENSORS

The following regulation procedure is for photoelectric sensors with N.O. output state, for photoelectric sensors with N.C. output state, the LED conditions are the opposite.

#### Diffuse reflective

- Mount the photoelectric sensor in working position but do not fasten it completely.
- Supply power to the sensor.
- Position the object to be detected, making sure that the optical axis is perpendicular to the surface of the object. If the surface to be detected is shiny, incline the optical axis by a few degrees so that the specular reflection is blocked out.
- Set up the photoelectric sensor in the worst working conditions:
  - smaller object to be detected;
  - darker object or part of object;
  - object in the furthest possible position in relation to the photoelectric sensor;

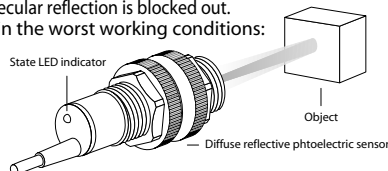

- If the state LED indicator is off, move the photoelectric sensor towards the object to be detected until the LED lights up. If the LED is already illuminated, move the photoelectric sensor away until the state LED goes off and then move it nearer again until when it re-lights up (position A).
- If there is no background go to point 6.1. If there is background go to point 6.2.
- NO BACKGROUND: move the photoelectric sensor nearer to the object by a distance of 15% of the detection distance.
- BACKGROUND PRESENT: remove the object to be detected (the LED will go off, if it does not go off, proceed to point 6.3) and move the photoelectric sensor towards the background until the state LED lights up (position B). Position the photoelectric sensor at a distance between position A (determined in point 5) and position B where the LED goes off.
- If the photoelectric sensor still detects the background, one solution may be to incline the optical detection axis in relation to the normal of the plane of the background by about 10° and repeat the setting procedure from point 4 onwards. If the LED still does not go off with this procedure, a model of photoelectric sensor with a more restricted range will have to be chosen.
- The system should then be securely fixed in place.

#### Retro reflective - Polarized retro reflective

- Fit the photoelectric sensor and the reflector facing each other within the operating range (distance determined by the kind of reflector used; see table at page 35).
- Supply power to the sensor.
- Carefully align the photoelectric sensor and reflector unit around the optical axis in order to set limits of the operation area and position the photoelectric sensor approximately at the centre.

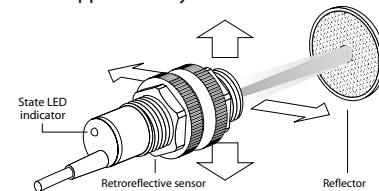

- Make sure that when an object is placed between the photoelectric sensor and the reflector, the state LED indicator lights up.
- The photoelectric sensor should switch when an obstacle, placed in proximity to the retroreflective, obscures at least 30/40% of its surface. If switching occurs with less darkness, align the photoelectric sensor and the retroreflective better so that the above condition is achieved.
- The system should then be securely fixed in place.

#### DETECTION OF REFLECTING OBJECTS

When the object to be detected is particularly reflective, polarized retroreflective sensors should be used. In any case, the photoelectric sensor should be orientated as in the diagram in order to avoid false reflections given by the object.

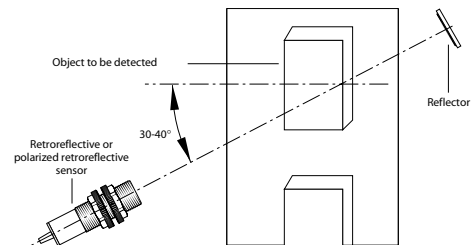

N. B.: The reflex and polarized reflex photoelectric sensors should never be used for maximum range values in the presence of adverse environmental conditions (such as dust, smoke, etc.) which could reduce the efficiency of the sensors.

#### Emitter - Receiver Thru-beam

- Fit the emitter and the receiver facing each other within the indicated operating range.
- Supply power to the two photoelectric sensors.
- Align the emitter and receiver carefully: orientate the receiver around the optical axis in order to set the limits of the operation area and position the receiver approximately at the centre.

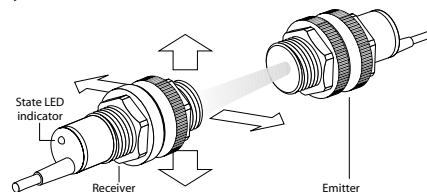

- Make sure that when an object is placed between the emitter and receiver, the state LED indicator lights up.
- The photoelectric sensor should switch when an obstacle, placed in proximity to the receiver, obscures at least 30/40% of its surface. If switching occurs with less darkness, align the emitter and the receiver better so that the above condition is achieved.
- The system should then be securely fixed in place.

N. B.: The emitter and receiver barriers should never be used for maximum range values in the presence of adverse environmental conditions (such as dust, smoke, etc.) which could reduce the efficiency of the sensors.

## GENERAL SPECIFICATIONS

### SETTING OF ADJUSTABLE PHOTOELECTRIC SENSORS

The following regulation procedure is for photoelectric sensors with N.O. output state, for photoelectric sensors with N.C. output state, the LED conditions are the opposite.

#### Diffuse reflective

- 1) Mount the photoelectric sensor in working position but do not fasten it completely.
- 2) Supply power to the sensor.
- 3) Position the object to be detected, making sure that the optical axis is perpendicular to the surface of the object. If the surface to be detected is shiny, incline the optical axis by a few degrees so that the specular reflection is blocked out.
- 4) Set up the photoelectric sensor in the worst working conditions:
  - smaller object to be detected;
  - darker object or part of object;
  - object in the furthest possible position in relation to the photoelectric sensor;
- 5) Turn the sensitivity adjustment trimmer clockwise (+) until maximum sensitivity is reached: the yellow LED should be illuminated; if this is not the case adjust orientation and/or bring the photoelectric sensor nearer.

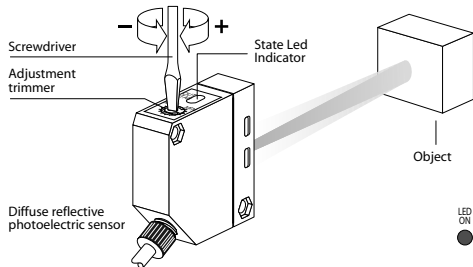

- 6) Turn the adjustment trimmer anticlockwise (-) until the LED goes out.
- 7) Turn the adjustment trimmer clockwise (+) until the LED lights up again (hysteresis recovery); this determines point A.
- 8.0) If there is no background go to point 8.1. If there is background go to point 8.2.
- 8.1) NO BACKGROUND: turn the trimmer to a position between point A and the extreme clockwise position (determined in point 5).
- 8.2) BACKGROUND PRESENT: remove the object to be detected (the LED will go out: if it does not go out proceed to point 8.3) turn the trimmer clockwise until the state LED lights up (point B). Turn the trimmer to a position between point A and point B where the LED goes out.
- 8.3) If the photoelectric sensor still detects the background, one solution may be to incline the optical detection axis in relation to the normal of the plane of the background by about 10° and repeat the adjustment procedure from point 5 onwards. If, with this procedure, the LED still does not go off in the presence of background, the photoelectric sensor should be moved nearer the object to be detected and the adjustment procedure from point 5 onward should be repeated.
- 9) The system should then be securely fixed in place.

#### Retro reflective - Polarized retro reflective

- 1) Fit the photoelectric sensor and the reflector facing each other within the operating range (distance determined by the kind of reflector used; see table on page 31).
- 2) Supply power to the sensor.
- 3) Make sure that the sensitivity adjustment trimmer is in the extreme clockwise position (+) and carefully align the photoelectric sensor and reflector around the optical axis in order to set the limits of the operation area and position the photoelectric sensor approximately at the centre until the LED goes out.

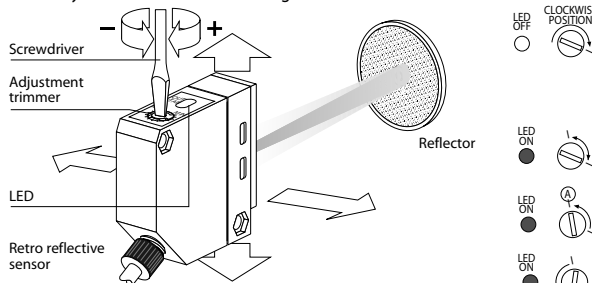

- 4) Slowly turn the adjustment trimmer anticlockwise (-) until the LED lights up and then improve orientation so that the LED goes off. Once better orientation is achieved, turn the trimmer clockwise (+) until the extreme clockwise position.
- 5) Position the object to be detected between the photoelectric sensor and the reflector and check that the yellow LED is illuminated, if the yellow LED is off, turn the trimmer anticlockwise (-) until the yellow LED lights up: point A.
- 6) Remove the object and gradually turn the trimmer anticlockwise (-) until the yellow LED lights up: point B.
- 7) Position the adjustment trimmer half way between point A and point B in order to achieve the ideal position.
- 8) The system should then be securely fixed in place.

### DETECTION OF REFLECTING OBJECTS

When the object to be detected is particularly reflective, polarized retroreflective sensors should be used. In any case, the photoelectric sensor should be orientated as in the diagram in order to avoid false reflections given by the object.

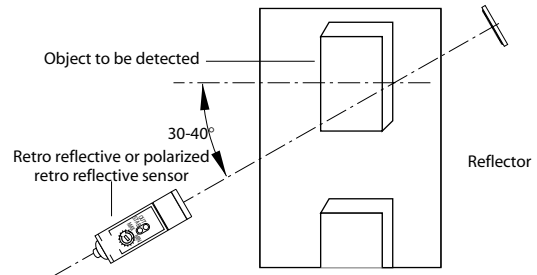

**N. B.:** The adjustment obtained in point 7 is the most efficient for shiny and/or semi-transparent objects; if the objects to be detected are opaque and non-reflecting, the trimmer can be brought to the extreme clockwise position which will allow the photoelectric sensor to operate even in very dusty environments.

### Emitter - Receiver Thru-beam

- 1) Fit the emitter and the receiver facing each other within the indicated operating range.
- 2) Supply power to the two photoelectric sensors.
- 3) Make sure that the sensitivity adjustment trimmer of the receiver is in the extreme clockwise position (+) and carefully align the emitter and receiver: orientate the receiver around the optical axis in order to set the limits of the operation area and position the receiver approximately at the centre until the state LED indicator on the receiver goes out.

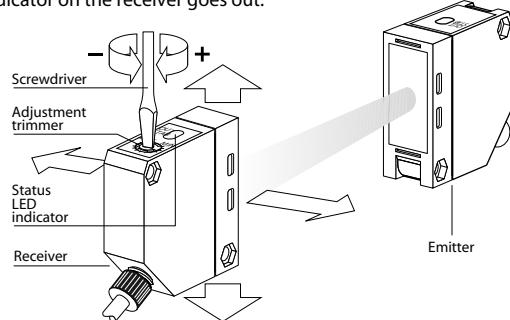

- 4) Position the object to be detected between the emitter and the receiver and check that the yellow LED on the receiver is illuminated, if the yellow LED is off, turn the trimmer anticlockwise (-) until the yellow LED lights up: point A.
- 5) Remove the object and gradually turn the trimmer anticlockwise (-) until the yellow LED lights up: point B.
- 6) Position the trimmer half way between point A and point B in order to complete adjustment.
- 7) The system should then be securely fixed in place.

**N. B.:** The adjustment obtained in point 6 is the most efficient for obtaining maximum sensitivity in the detection of small and semi-transparent objects; if the objects to be detected are opaque and are larger than the lens, the trimmer should be turned to the extreme clockwise position which will allow the photoelectric sensor to operate even in very dusty environments.

### Optical brackets

- 1) Mount the optical brackets in working position and fasten it completely.
- 2) Supply power to the optical brackets.
- 3) NO SENSING OBJECT Turn the trimmer clockwise (9 full turns) to confirm the status (yellow LED is off).
- 4) Position the object to be sensed and check the yellow LED is on. If the yellow LED is off, turn the trimmer anti-clockwise and find point "A" where the yellow LED is on.
- 5) Remove the object and turn the trimmer anti-clockwise and find point "B" where the yellow LED is on.
- 6) Set the trimmer to half way between points "A" and "B" for the adjustment is completed.

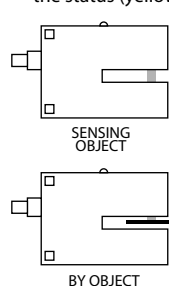

### Further information

Although some ranges of INFRA photoelectric sensors are protected to IP67, this does not mean that our devices can be used to detect objects in water or in the rain.



# Photoelectric Sensors

## GENERAL SPECIFICATIONS

### DEFINITIONS AND TERMINOLOGY FOR PHOTOELECTRIC SENSORS

n.	THERMINOLOGY			DESCRIPTION
1	PHOTOELECTRIC SENSOR	-	-	Photoelectric Sensor: device sensitive to direct or reflected visible or infra-red light radiation; it can detect the presence of an object (target) in a fixed area (sensing area) by means of the reflection or the interruption of the beam projected in the sensing area.
1.1	PHOTOELECTRIC SENSOR STATUS	NOT SUPPLIED	-	Photoelectric Sensor without electrical power supply and therefore out of order. Solid state outputs are in a not defined condition; relay outputs correspond to the not activated relay condition (relay off).
1.2	PHOTOELECTRIC SENSOR STATUS	SUPPLIED	NOT ACITVATED	Photoelectric Sensor properly supplied and therefore working with no target; particularly: - diffuse reflective sensor with no target in the sensing area; - retro reflective sensor or thru beam with aligned beam and not interrupted beam by a target; the outputs status called "normal" (i.e. <i>output N.O. : output normally open; output N.C. : output normally closed</i> ) refers to this photoelectric sensor condition.
1.3	PHOTOELECTRIC SENSOR STATUS	SUPPLIED	ACITVATED	Photoelectric Sensor properly supplied and therefore working with target ; particularly: - diffuse reflective sensor with target in the sensing area; - retro reflective sensor or thru beam with not aligned beam or interrupted beam by a target.
1.4	LIGHT ON	-	-	It shows for the photoelectric sensor the case of reception of direct or reflected light.
1.5	LIGHT OFF	-	-	It shows for the photoelectric sensor the case of failure in receiving the direct or reflected light.
2	OUTPUT	IN SOLID STATE	-	It corresponds to a transistor collector that is to say a triac anode or to a scr anode according to the electrical power supply ( d.c. or a.c.).
2.1	OUTPUT	IN SOLID STATE	PNP	Output in solid state with pnp transistor; when it is activated, it supplies a positive voltage whose reading is near the supply positive pole (+).
2.2	OUTPUT	IN SOLID STATE	NPN	Output in solid state with npn transistor; when it is activated, it supplies a negative voltage whose reading is near the supply negative pole (-).
2.3	OUTPUT	IN SOLID STATE	ON (ACTIVATED)	Activated output in solid state, it supplies on the load an output voltage whose reading is near to the voltage power supply of the same Photoelectric Sensor.
2.4	OUTPUT	IN SOLID STATE	OFF (NOT ACTIVATED)	Not activated output in solid state; the load, which is connected to it, does not receive any voltage; a not considerable leakage current can be present.
2.5	OUTPUT	IN SOLID STATE	N.O.	Output in solid state in off status (not activated) when the Photoelectric Sensor is in "normal" condition, that is to say not activated.
2.6	OUTPUT	IN SOLID STATE	N.C.	Output at solid state in on status (activated) when the Photoelectric Sensor is in "normal" condition , that is to say not activated.
3	OUTPUT	RELAY	-	It corresponds to a relay contact isolated from the Photoelectric Sensor power supply.
3.1	OUTPUT	RELAY	N.C.	Closed contact when the Photoelectric Sensor is in "normal" condition, that is to say not activated.
3.2	OUTPUT	RELAY	N.O.	Open contact when the Photoelectric Sensor is in "normal" condition, that is to say not activated.
4	OUTPUT RELAY	NOT ACTIVATED (OFF)	-	Relay in not working condition and therefore not switched.
4.1	OUTPUT RELAY	ACTIVATED (ON)	-	Relay in working condition and therefore switched.