

FRS 120 / FRS 180 / FRS 250



- Spread : 120 to 250 mm
- Supply : 24 VDC
- Outputs : PNP / NPN
- Minimum object size detected : 10 mm



Description :

- Cheap product designed to detect any part in a spread from 120 x 200 mm to 250 x 200 mm
- Minimum object size detected : 10 mm
- Output : PNP / NPN / LO / DO
- Painted aluminium strong housing

Applications :

- Count of parts.
- Ejection safety control from a plastic press.
- Parts detection through a translucent pipe.
- Detection of parts by gravity.

Dimensions and Visualisation

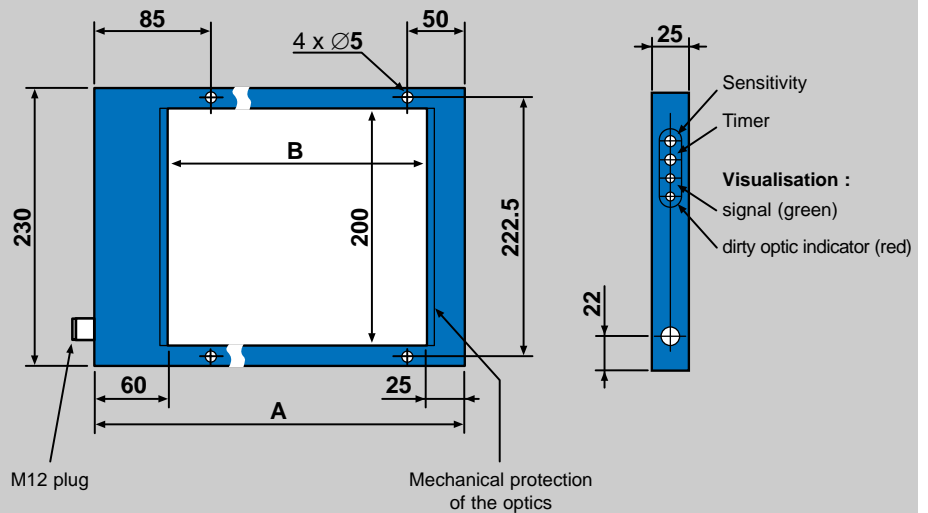

- In case of a faulty supply, the red LED flashes.
- In case of a short-circuit on an output, the red and green LEDs flash.

TYPE	A (mm)	B (mm) : spread
FRS 250	335	250
FRS 180	265	180
FRS 120	205	120

Wiring Connections

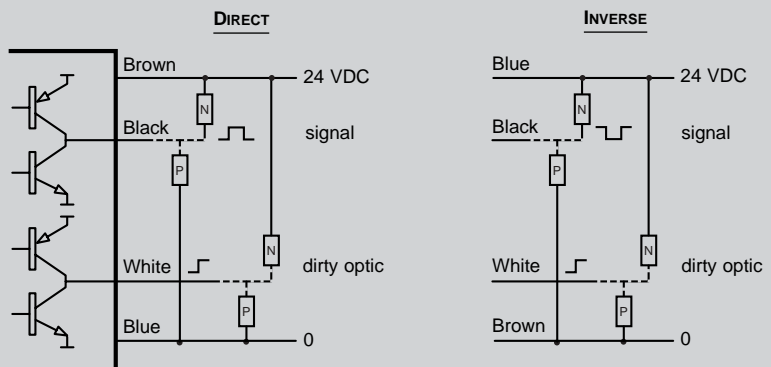

Technical Information

Supply	voltage	18 to 30 VDC ripple < 10% within specified limits
	consumption	400 mA
Response time	t _{on} or t _{off}	1 ms
	switching frequency	500 Hz
Outputs	max. nominal intensity	100 mA
	residual voltage at 100 mA	< 2 V
	residual voltage at 10 mA	< 1 V
Emission	LED	infra-red
Timer	retriggerable OFF-delay	max. 5 s
Temperature	operating	0 to 60 °C
	storage	-20 to 80 °C
External light immunity	incandescent light	400 lux
	sunlight	4 000 lux
Protections	output	permanent short-circuit or over-load protection
	degree of protection	IP 65
Minimum size of detection		∅ 10 mm
Object speed	minimum	10 cm/s ∅ 10 mm
	maximum	15 m/s ∅ 10 mm

To Place Order

Product	Frame sensor
Reference	FRS - () - S - 24 VDC
Type	
spread 120 x 200 mm	(120)
spread 180 x 200 mm	(180)
spread 250 x 200 mm	(250)

TYPES OF APPLICATIONS

Example 1

Ejection control at the output of a press.

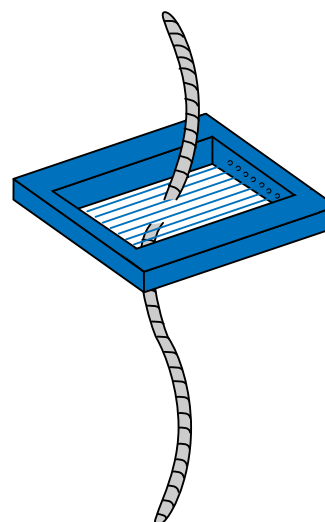
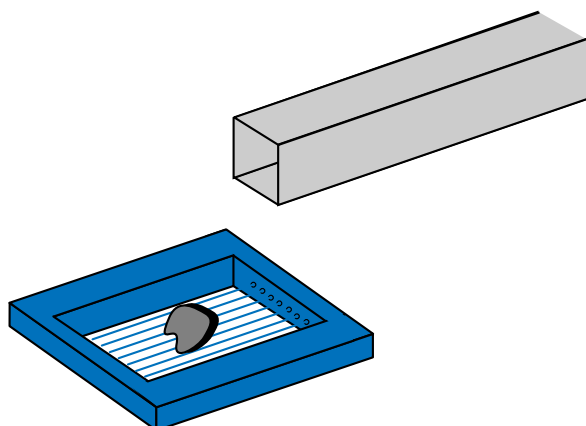

Example 2

Break detection of a string or a rope.