



# Hall Effect Magnetic Sensors Ø 9

## HALL EFFECT MAGNETIC PROXIMITY SENSORS 12÷30 VDC PNP OUTPUT

- Three-wire sensors
- Fast 50 µS ON/OFF
- Sensing models: *Front end travel*  
*Bilateral side travel*  
*Choice of magnet targets*
- PNP NC or NO

## HS Series



### Identification code

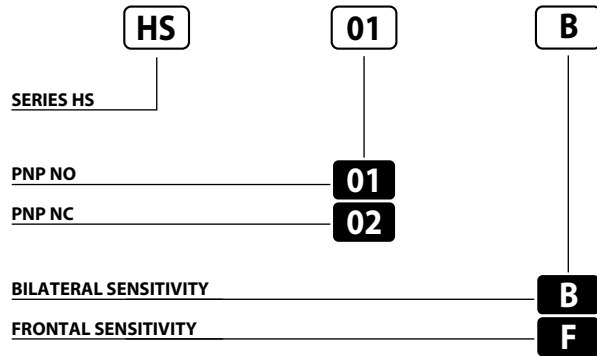

### Wiring diagrams

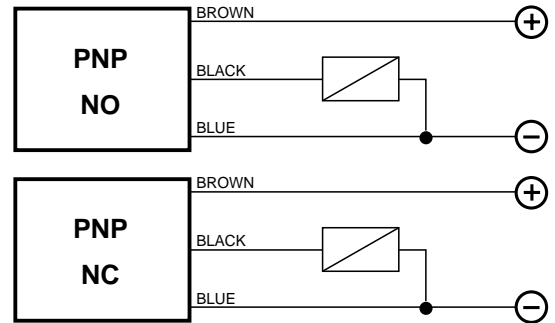

MAGNETIC FLUX (Gauss)	
• SENSOR ON	≥ 25 (Tip. 15 at 25°C)
• SENSORE OFF	≥ 5 (Tip. 11 at 25°C)
• HYSTERESIS	Max. diff. 7 (Tip. 4 at 25°C)
NOMINAL VOLTAGE	12 ÷ 30 VDC (-15/+10%)
RESIDUAL RIPPLE	≤ 10%
MAX. CURRENT OUTPUT	200 mA
ABSORPTION AT 30 VDC	≤ 10 mA
VOLTAGE DROP (Sensor ON)	< 1.8 V
YELLOW LED	Output indicator
GREEN LED	Supply indicator
SWITCHING FREQUENCY (max.)	10 kHz
TIME RESPONSE	100 µS
START UP DELAY	50 mS
SHORT CIRCUIT PROTECTION	Present (self-resetting)
ELECTRIC PROTECTIONS	Against reversal polarity - inductive loads
TEMPERATURE LIMITS	- 20 ÷ +60 °C
PROTECTION DEGREE	IP 67
CABLE LENGTH	2 m
CABLE SECTION	3 x 0.25 mm <sup>2</sup>
HOUSING MATERIAL	Nickel-plated brass
WEIGHT (Approximately)	50 g

### Hall effect sensor / magnet switching distance (mm)

DIAMETER 9  
Distance Hysteresis

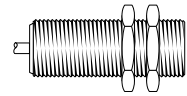

33	4	MG01
30	4	MG02
18	5	MG03
41	6,5	MG04
35	7	MG05

**WARNING:** The data specified in this table have an approximate value because they depend on the magnet position, on the material on which it is applied (ferromagnetic or not) and because they are related to the magnet during the frontal approach.

### Dimensions (mm)

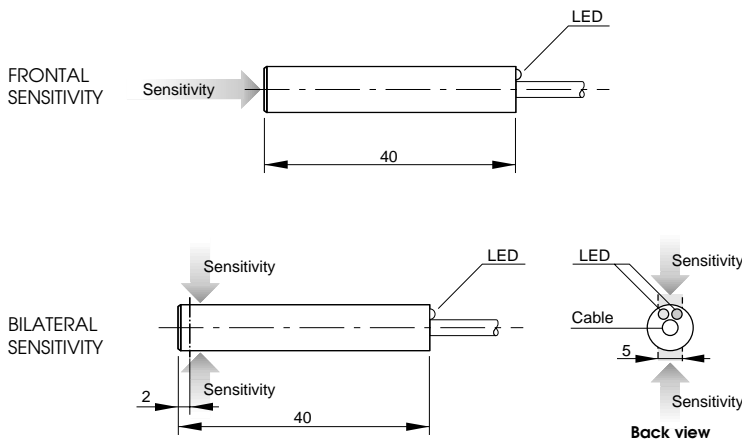

### Magnets dimensions (mm)

