



LR652



Operating Instructions



This product is an accessory or part of a system. Always read and follow the manufacturer's instructions for the equipment you are connecting this product to. Comply with all applicable codes and safety regulations. Failure to do so may result in damage, injury or death!

Product Overview

The LR652 wireless receiver meets the growing demand for receivers with multiple and independently controlled output functions. These RF receivers are compatible with both code hopping and fixed code transmitters (see page 6 of this manual for a list of compatible transmitters). The receivers can be used to control a variety of home automation devices such as garage door openers, lights, motorized gates, lifts, or other devices remotely.

Installation Notes

1. Mount the receiver out of sight in a location where it is not exposed to weather or moisture and where it is not surrounded by metal. Metal will block the RF signal, resulting in reduced range.
2. For best results pull the wire antenna as long and straight as possible. If the receiver receives interference from local RF activity (e.g., airport or military base.) the antenna wire can be folded to reduce interference.

IMPORTANT: DO NOT CUT THE ANTENNA WIRE

Technical Specifications

Power Supply	11 – 24 Volts AC / DC
Current	8 mA standby 30mA @ 12VDC activated per channel
Relay	Form C 10A @ 24VDC or 120VAC
Operating Frequency	315 MHz
Operating Range	Up to 500 feet
Operating Range with Optional Dipole Antenna	Up to 1000 feet
Number of Codes in memory	15 per channel FIFO register (code 16 will delete first code put in)
Dimensions	3.125" x 2.563" x 1.0" (80mm x 65mm x 25mm)
Possible codes	68 billion
Connections	Screw terminal

Connections

#1 Power + 11 – 24 V AC/DC

#2 Power - 11 – 24V AC/DC

#3 Normally Open relay 1 contact

#4 Normally Closed relay 1 contact

#5 Common relay 1 contact

#6 Normally Open relay 2 contact

#7 Normally Closed relay 2 contact

#8 Common relay 2 contact



Programming Remotes

Each receiver channel can learn the codes of up to 15 different transmitters on a first-in, first-out basis.

Below is the procedure for teaching a new transmitter button.

1. Press the channel mode switch for 3 seconds or more. The channel LED will start to flash quickly to indicate that it is in programming mode.
2. While the LED is flashing press the button of the transmitter to be learned one time. The receiver LED will flash once to indicate the code has been successfully learned. After the transmitter has been learned the receiver will automatically exit programming mode. To add additional transmitters repeat step 1 and 2 as necessary. See picture below for example.

Note: The LED will flash for a maximum of 15 seconds. If no transmitter button is pressed during this time the receiver will exit programming mode and the LED will turn off.

Only fifteen individual codes may be “learned“ by the LR-650. If you enter a sixteenth code the first code entered will be removed from memory.

If the code being learned is already in the system the LED will turn on steady and then begin flashing again. The code will not be learned the second time.

3. To clear all codes from the LR-650 memory press the mode switch for 3 seconds or until the LED flashes. Release, then press the mode switch for 3 seconds or more and the LED will stop flashing. The LED will then flash twice to indicate that all codes have been deleted.
4. To Display how many codes are in the LR-650 memory, press and release the mode switch once. The LED will flash once for each code in memory (e.g. 10 flashes equal 10 codes)

Note: Follow steps 1 – 4 as needed for Channel #2



Programming Relay Functions

The LR-650 has five output functions that may be programmed by the use of the program switch (indicated by the arrows) in the picture bottom right. Functions may be programmed based on user needs:

1. **4 Second Timed Output** (default). When the transmitter button is pressed the relay will energize for 4 seconds.
2. **Toggle Output** Press the transmitter button once and the relay turns on. Press again and the relay turns off.
3. **Latch Output** Press the transmitter button one and the relay stays on even if another programmed transmitter button is pressed. The relay may only be turned off by pressing the Mode button (referenced above).
4. **Validity Output** The relay will turn on for as long as the transmitter button is pressed. Note: Due to interference or low transmitter battery power the signal may be lost and allow the relay to turn off.
5. **1 Second Timed Output** When the transmitter button is pressed the relay will turn on for 1 second.

Instructions on next page

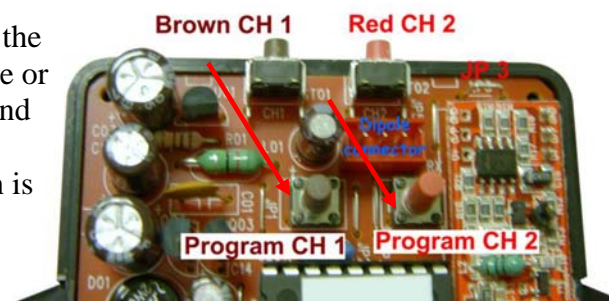
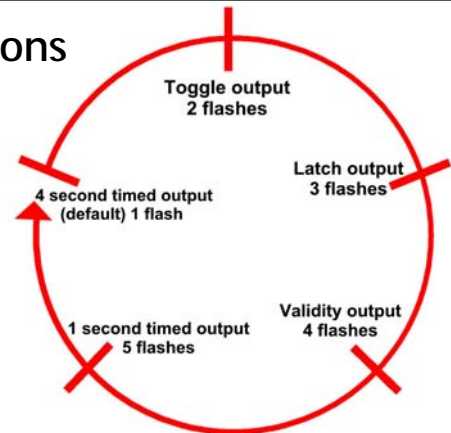

Programming Relay Functions (continued)

Selecting the relay output mode

Remove the top cover by depressing the tabs in the bottom cover at the mounting tabs.

- Hold down the function switch (see location in picture bottom right of page 3) for 3 seconds, the LED will blink indicating the current output mode.
- To change the function, press the function switch. Each press of the function moves the program to the next function. (see diagram on bottom right page 3). To change from 4 second default to 1 second output you would press and hold the function switch until the LED blinks, then press the function switch 4 more times.
- After you have changed the output function count the blinks of the LED to verify the desired function has been selected.
- To exit the programming press the function switch for 3 seconds or wait for it to time out in 15 seconds.

Installing the Optional LR-650-Dipole

To use the LR-650-Dipole you must remove the top cover as explained above.

Plug the polarized lead from the antenna into the Red connector shown in picture below, location (Dipole Connector).

You must then cut LP3 shown in picture below, location (JP 3).

Note: antenna range will vary greatly depending on the operating environment. Do not mount on metal poles or surfaces as these will reduce or prevent the signal from being detected. Mount the antenna as high as possible for best reception and range.



Sample Wiring Connections

- Using the Toggle Mode to turn on a light or other AC powered device up to 10 Amp current draw.

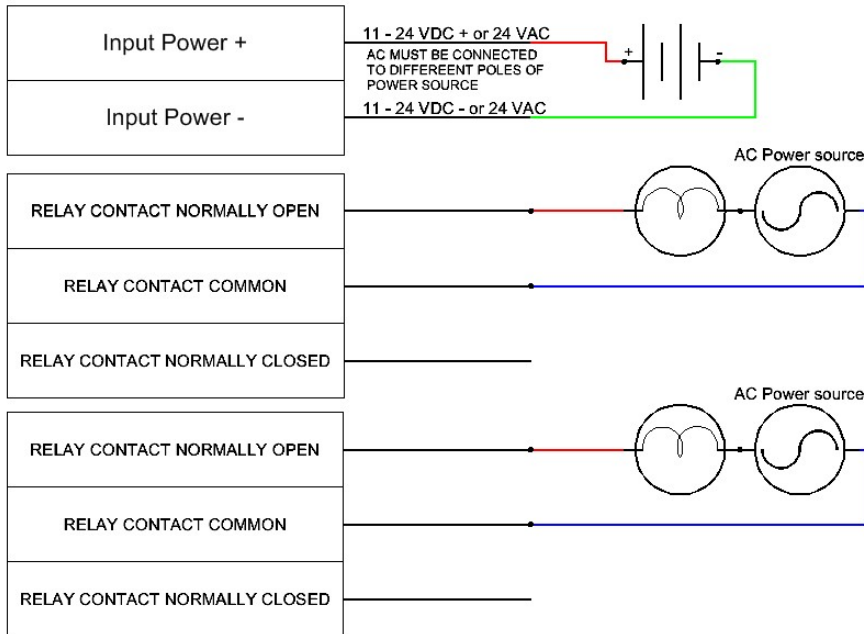

- To open a gate or door using channel 1 and close with channel 2.

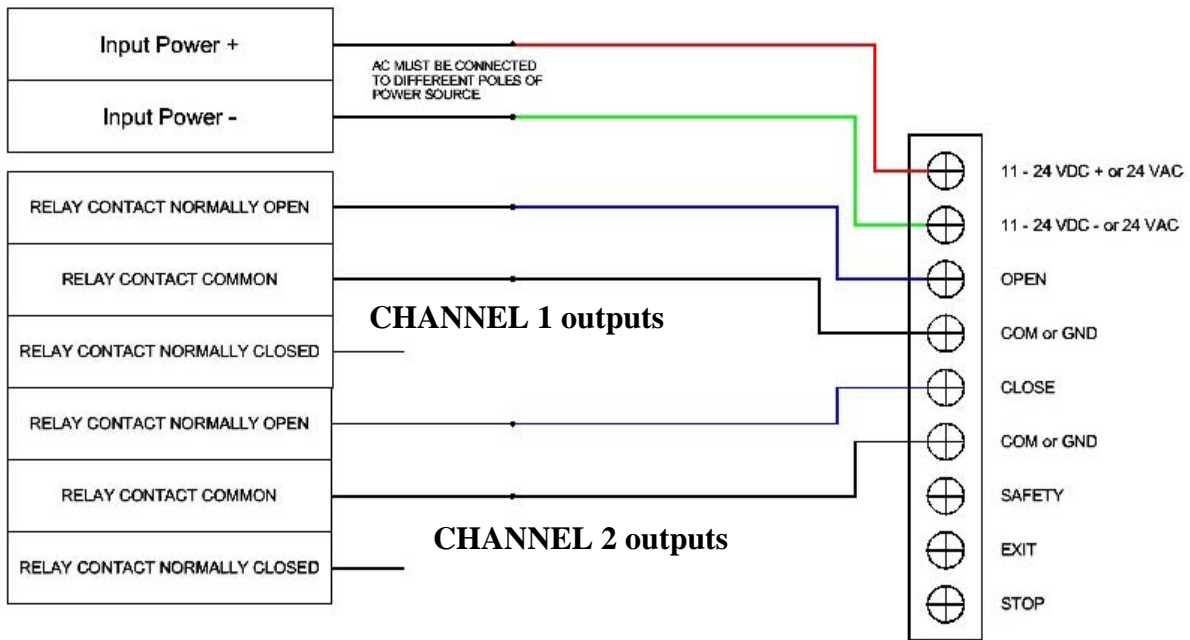

Trouble Shooting Guide

Problem	Possible cause	Solution
Does not detect transmitter	Low battery power in transmitter	New battery in transmitter
	Antenna wire is still folded	Straighten antenna wire
	Signal is blocked by obstruction	Make sure unit is not mounted on or inside metal or near magnetic source i.e. motors.
	Beyond normal operating range	Add optional Dipole antenna
	No power	Check proper power is at terminals
	Transmitter is not in memory	Program as per top of Page 3
Detects transmitter but does not activate gate	Broken wire	Check for wire continuity
	Improper terminal connection	Jumper input terminals to assure they activate operator as desired
	Relay failure	Contact installer or point of purchase

Ordering and Accessories

LR-650-RX	Long Range receiver
LR-650-TX	Single button Key fob transmitter
LR-650-TX1B/VC	Single button Visor Clip transmitter
LR-650-TX2B/VC	Two button Visor Clip transmitter
LR-650-TX4B/VC	Four button Visor Clip transmitter
LR-650-RX-4X	Long Range receiver in NEMA 4 housing
LR-652-RX	Long Range Receiver 2 channel (May be used with LR650 transmitters)
LR-652-TX	Two button Key fob transmitter (May be used with the LR-650 receivers)
LR-DIPOLE	Extended range dipole antenna with 9 feet of lead wire

Installer Notes Please record transmitter codes to help us in the event you need replacements

Transmitter Codes	Channel 1
	1
	2
	3
	4
	5
	6
	7
	8
	9
	10
	11
	12
	13
	14
	15

Transmitter Codes	Channel 2
	1
	2
	3
	4
	5
	6
	7
	8
	9
	10
	11
	12
	13
	14
	15

EMX

INDUSTRIES, INC.

4564 Johnston Parkway
Cleveland, Ohio 44128
United States of America
WEB <http://www.emxinc.com>
E-mail salesupport@emxinc.com
Telephone (216) 518-9888
Fax (216) 518-9884

